



HA16 SPX HA18 SPX

Optimal productivity

- Full proportional controls and simultaneous boom functions
- Lifts to full height in 44 seconds

Outstanding rough terrain driving features

- 4 wheel drive means greater manoeuvrability
- Hydraulic differential lock
- 38 cm ground clearance

9.15 metre outreach provides a large working envelope (HA16SPX)



Haulotte 
GROUP

More than lifting





HA16 SPX / HA18 SPX



ROUGH TERRAIN ARTICULATING BOOMS

HA 18 SPX
HA 16 SPX

TECHNICAL DATA

HA16 SPX **HA18 SPX**

Working height	16 m	17.3 m
Platform height	14 m	15.3 m
Horizontal outreach	9.15 m	10.6 m
Up and over clearance	6.5 m	6.5 m
Lift capacity	230 kg	230 kg
F x G Platform size	1.8 x 0.8 m	1.8 x 0.8 m
A Length	6.8 m	7.5 m
Transport length	5.15 m	5.8 m
B Width	2.3 m	2.3 m
C Height - stowed	2.2 m	2.2 m
Transport height	2.55 m	2.55 m
Vertical jib rotation	140° (+70/-70)	140° (+70/-70)
Platform rotation	180° (+90/-90)	180° (+90/-90)
Turntable rotation	350 °	350 °
Tailswing	0 m	0 m
D Wheelbase	2 m	2 m
E Ground clearance	38 cm	38 cm
Tilt	5 °	5 °
Drive speed	0.8 - 5.5 km/h	0.8 - 5.5 km/h
Gradeability	40 %	40 %
Turning radius - outside	4.5 m	4.5 m
Tires - foam-filled	14-17.5	14-17.5
Power source	31.2 kW - 42.hp	31.2 kW - 42.4 hp
Hydraulic system capacity	100 l	100 l
Fuel tank capacity	72 l	72 l
Weight	6700 kg	7660 kg

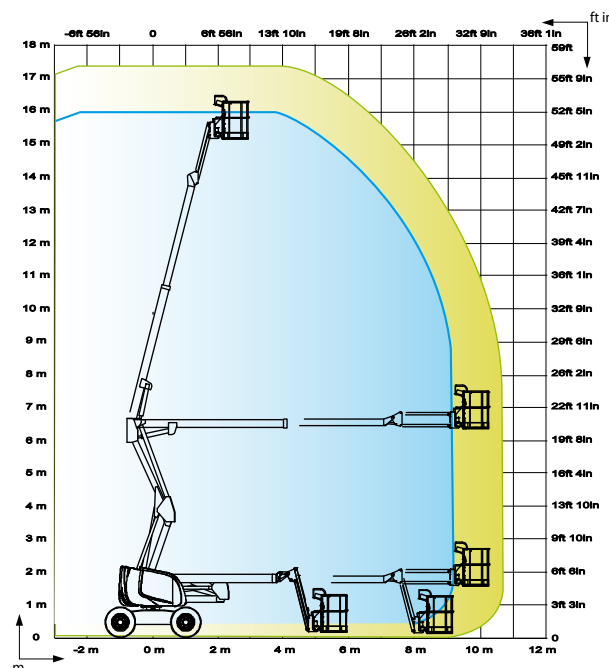

STANDARD EQUIPMENT

- 4 wheel drive (2 wheel steer)
- 350° turntable
- Safe to use in winds up to 45 km/h
- Swing out engine tray for ease of maintenance
- 72 l fuel tank; 1.50 m filling height
- 5° tilt alarm
- 12 V battery / electrical control system
- Auxiliary power in the platform for emergency descent
- Brake release
- Hourmeter
- Slewing block pin
- Towing hooks / lifting eyes

OPTIONS AND ACCESSORIES

- 3.3 kW on-board generator
- Power to platform
- Large basket 2.3 x 0.80 m
- Travel alarm
- Rotating beacon
- Working light
- Catalytic exhaust
- Biodegradable hydraulic oil
- Cold Weather Package
- Warm environment kit
- Air line in platform

