

Model 600 SERIES

ARTICULATING BOOM LIFTS



Performance

Platform Height		
600A	60 ft 5 in.	18.42 m
600AJ	60 ft 7 in.	18.47 m
Horizontal Outreach		
600A	39 ft 7 in.	12.07 m
600AJ	39 ft 9 in.	12.10 m
Up and Over Clearance	26 ft 7 in.	8.1 m
Swing	360 Degrees Continuous	
Platform Capacity		
Restricted (600A)	1,000 lb	450 kg
Platform Capacity		
Unrestricted	500 lb	227 kg
Platform Rotator	180 Degrees Hydraulic	
Jib Range of Articulation (600AJ)	130 Degrees (+70, -60)	
Weight		
600A	21,640 lb	9,816 kg
600A Narrow	24,100 lb	10,931 kg
600AJ	22,240 lb	10,088 kg
600AJ Narrow	24,200 lb	10,977 kg
Max. Ground Bearing Pressure		
600A	77 psi	5.5 kg/cm ²
600A Narrow	94 psi	6.6 kg/cm ²
600AJ	75 psi	5.27 kg/cm ²
600AJ Narrow	94 psi	6.6 kg/cm ²
Drive Speed 2WD	4.25 mph	6.8 kph
Drive Speed 4WD	4.25 mph	6.8 kph
Gradeability 2WD	30%	
Gradeability 4WD	45%	
Axle Oscillation	8 in.	20.4 cm
Turning Radius Inside/Outside		
2WS	11 ft. 5 in./17 ft. 8 in.	3.48 m/5.38 m
4WS	5 ft. 6 in./11 ft. 8 in.	1.68 m/3.56 m
Narrow Models		
4WS	5 ft. 7 in./11 ft. 2 in.	1.7 m/3.4 m

Standard Specifications

Power Source

Dual Fuel Engine		
GM Vortec 3000 MPFI	82 hp	61 kw
Diesel Engine		
Deutz D2011L04	49 hp	36.5 kw
Fuel Tank Capacity	30 gal.	113.6 L

Hydraulic System

• Capacity	30.6 gal.	115.8 L
• Auxiliary Power	12V DC	

Tires

• Standard	14 x 17.5 Lug Tread
• Narrow Models	14 x 17.5 Air Boss
• Optional	Foam-Filled



Standard Features

- Oscillating Axle
- 180 Degree Hydraulic Platform Rotator
- 110V-AC Receptacle in the Platform
- 5 Degree Tilt Alarm/Indicator Light
- Swing-Out Engine Tray
- 12V-DC Auxiliary Power
- Hourmeter
- Horn
- Control ADE® System
- Proportional Controls
- Gull-Wing Engine Hood
- Platform Console Machine Status Light Panel*
- Lifting/Tie Down Lugs
- All Motion Alarm
- Glow Plugs (Diesel Engines)

* Provides indicator lights at platform control console for system distress, 5 degree tilt light, and foot switch status.

Accessories & Options

- Platform: 36 x 72 in. (0.91 x 1.83 m)
- Fall Arrest Platform, Rear Entry¹: 36 x 96 in. (0.91 x 2.44 m)
- Self-Closing Gate
- Mesh to Top Rail—Bolt-on Aluminum
- Soft Touch System
- Operator Tool Tray
- 43.5 lb (19.7 kg) Propane Tank
- Exhaust Purifier Muffler (Diesel)
- Cold Weather Start Kit²
- Hostile Environment Kit³
- Light Package⁴
- Platform Worklights
- Flashing Amber Beacon
- Arctic Package⁵
- Accessory Packages:
 - SkyPower®
 - SkyWelder®
 - SkyGlazier®
 - SkyCutter®
 - Pipe Rack

1. Foam-filled tires required.

2. Includes glow plugs (Diesel), battery heater, oil tank heater.

3. Includes console cover, boom wipers and cylinder bellows.

4. Includes head and tail lights, and platform worklights.

5. Includes arctic hydraulic hoses (drive and steer only) and main boom cable, arctic hydraulic oil, extreme cold engine oil, fuel conditioner, engine block heater, battery blanket, glow plugs, hydraulic tank heater, and oversized footswitch.

Model 600 SERIES

ARTICULATING BOOM LIFTS

Dimensions

All dimensions are approximate.

600A

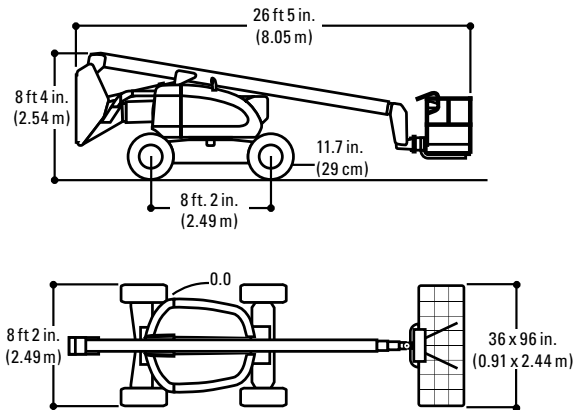

600AJ

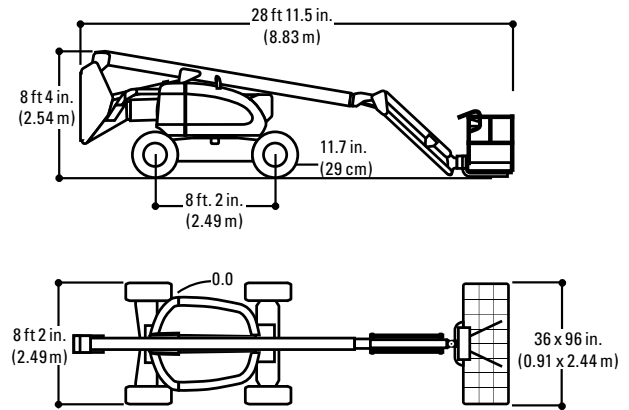

Reach Dimensions

600A

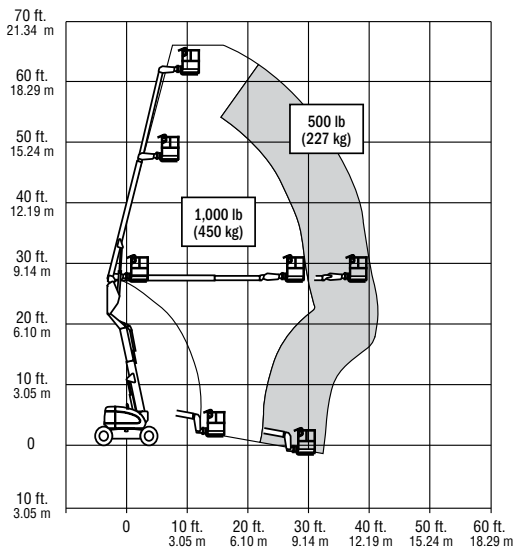

600AJ

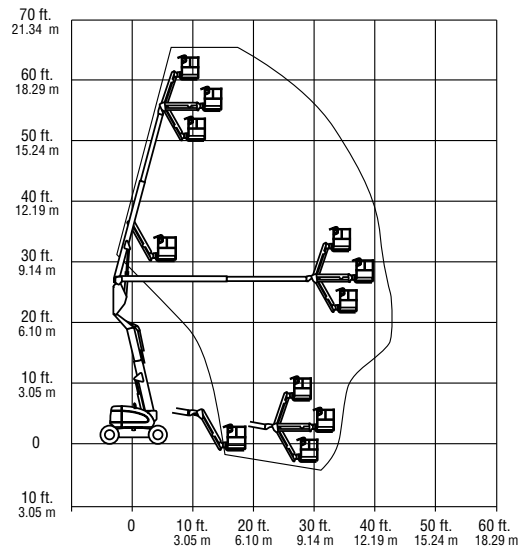

The JLG "1 & 5" Warranty

JLG Industries, Inc. backs our products with our exclusive "1 & 5" Warranty. We provide coverage for one (1) full year, and cover all specified major structural components for five (5) years. These machines meet or exceed applicable OSHA Regulations in 29 CFR 1910.67, 29 CFR 1926.453, ANSI A92.5-2006 and CSA standard B354.4-02 as originally manufactured for intended applications. We reserve the right to make price, specification, and/or equipment changes without prior notification.

Form No.: 1230ES-0107-10M
Part No.: 3131309
R081308
Printed in USA

JLG Industries, Inc.
1 JLG Drive
McConnellsburg, PA 17233-9533
Telephone 717-485-5161
Toll-free in US 877-JLG-LIFT
Fax 717-485-6417
www.jlg.com

An Oshkosh Corporation Company